



HAND PUMP

Model : HP 12 AND HP 16

Ref. No. D 04910
Release 11/2014

ENGINEERING - 1 of 2

A Polyhydron Group Company

Description

Hand pump model HP12 and HP16 are compact heavy duty pumps designed for Industrial applications like operating small presses fixtures as well as providing source of oil for emergency applications. These pumps can also be used at construction sites for operating jacks for repair work.

Hardened and ground piston and low friction high performance seal give the pump long service life.

The collapsible handle makes the pump easy to transport and reduce operating force when the handle is extended.

Special Air breather prevents airborne impurities from entering the tank, thereby enhancing the service life of the pump.

The pump can be supplied with extra large tank if needed.

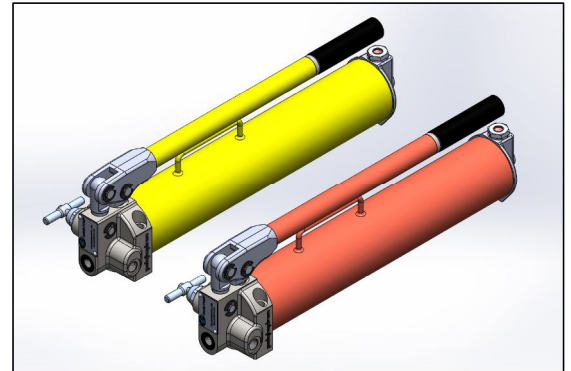

Unit dimensions

Dimensions in mm.

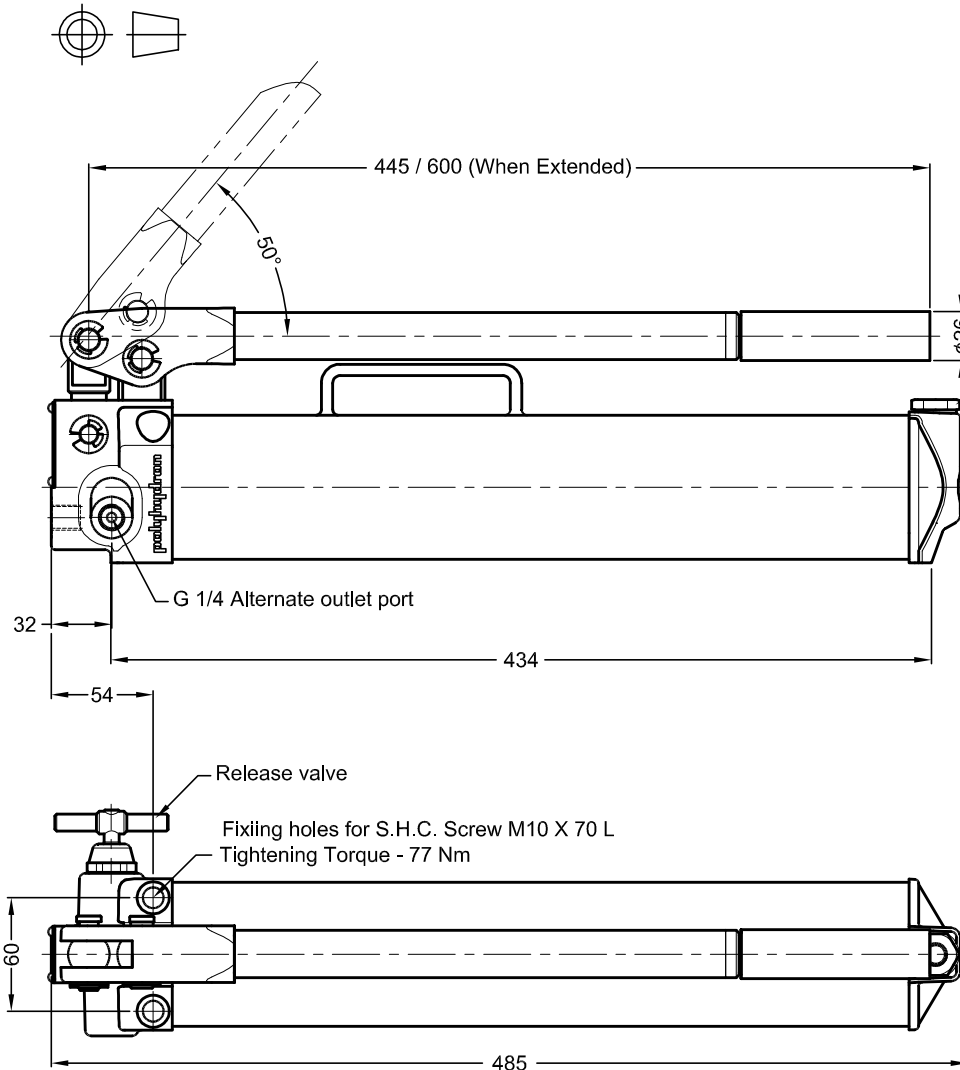

Hydraulic symbol

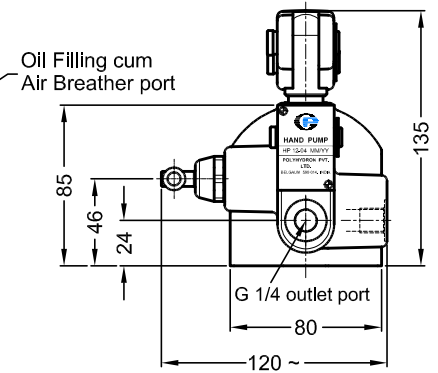
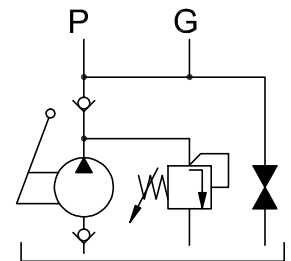

polyhydron pvt. ltd.

78-80, Machhe Industrial Estate,
Machhe, Belgaum - 590 014. INDIA.

Phone : +91-(0)831- 2411001
Fax : +91-(0)831- 2411002
E-mail : polyhydron@gmail.com
Website : www.polyhydron.com



Technical specifications

Construction	Sealed piston with ball type suction and delivery valve .
Hydraulic medium	Mineral oil.
Maximum working pressure.....	Refer table no.1
Displacement.....	Refer table no.1
Oil tank capacity.....	1.25 L
Oil tank displacement.....	0.8 L
Force required at the end of the hand lever at max. pressure (Approx).....	Refer table no.1
Vscosity range	10 cSt to 380 cSt
Fluid temperature range	-20°C to +70°C
Fluid cleanliness requirement	ISO 4406 20/18/15 or better.
Mass	With Oil 8.7 kg Without Oil 7.7 kg

Table no. 1

Specification	Unit	HP12	HP12-1000	HP16
Max. Working Pr.	bar	700	1000	350
Displacement Capacity	cm ³ /stroke	2.8	2.8	5
Force required at the end of the hand lever at max. Pressure (Approx)	N	385	550	340

Ordering code

